

7) Appearance and Dimensions

➤ Frame A

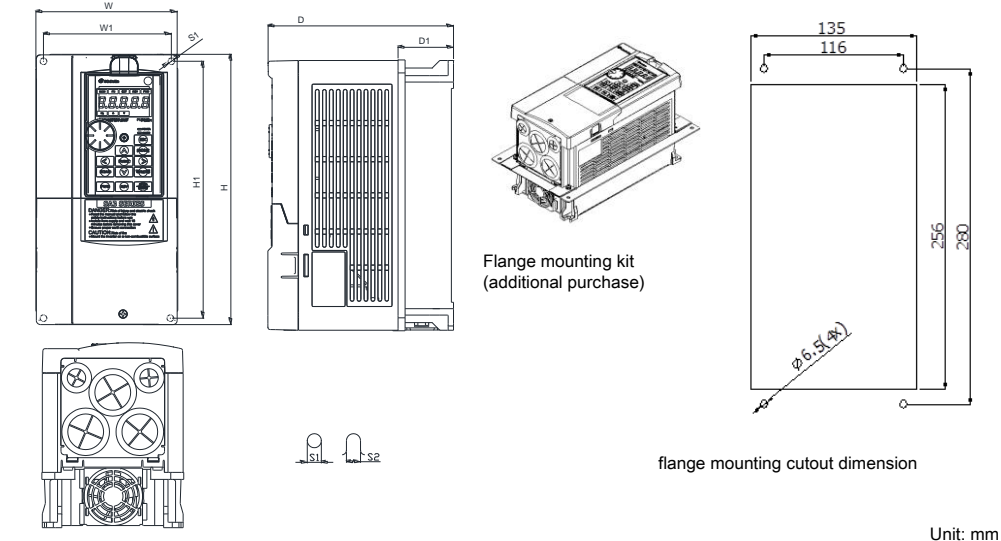

model	W	W1	H	H1	D	D1	S1	S2
SF3-043-5.5K/3.7KG	130.0	116.0	250.0	236.0	170.0	51.3	6.2	6.2
SF3-043-7.5K/5.5KG								

➤ Frame B

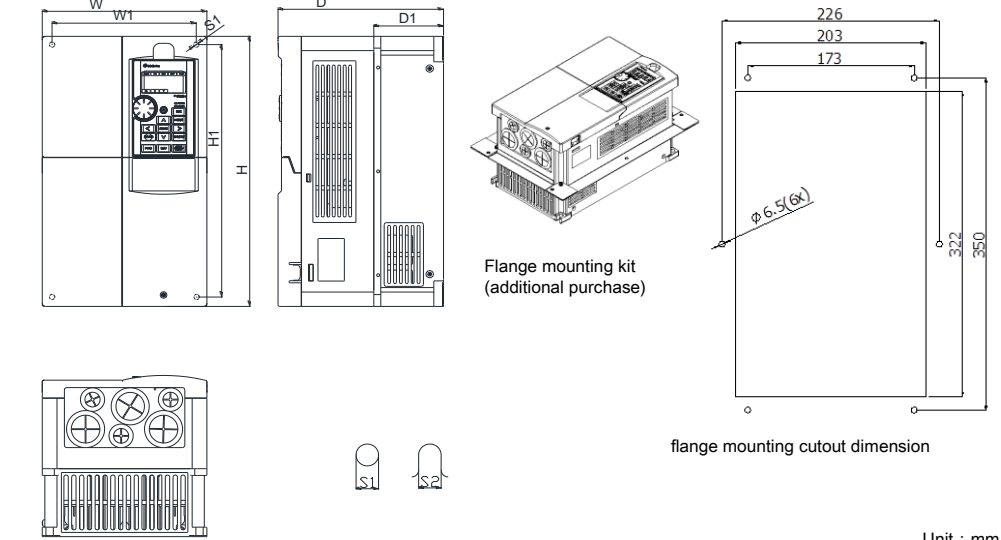

model	W	W1	H	H1	D	D1	S1	S2
SF3-043-11K/7.5KG	190.0	173.0	320.0	303.0	190.0	80.5	8.5	8.5
SF3-043-15K/11KG								
SF3-043-18.5K/15KG								

➤ Frame C

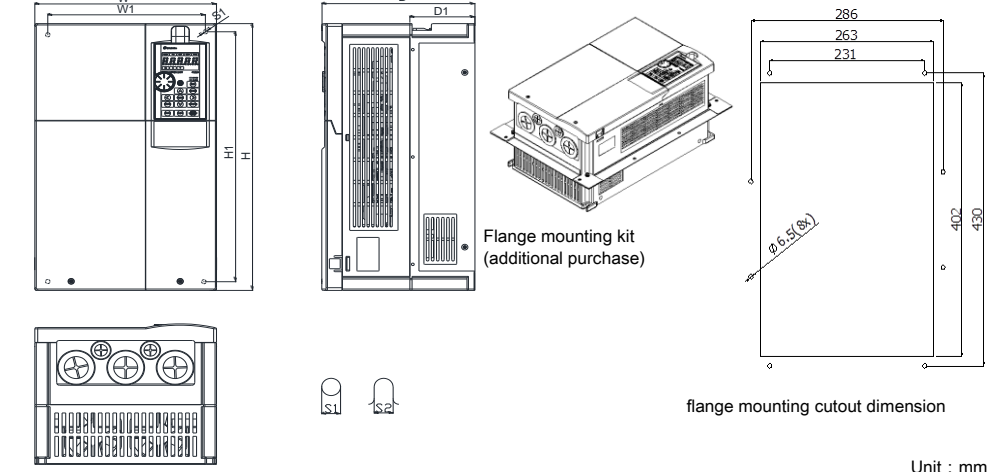

model	W	W1	H	H1	D	D1	S1	S2
SF3-043-22K/18.5KG	250.0	231.0	400.0	381.0	210.0	89.5	8.5	8.5
SF3-043-30K/22KG								
SF3-043-37K/30KG								
SF3-043-45K/37KG								

➤ Frame D

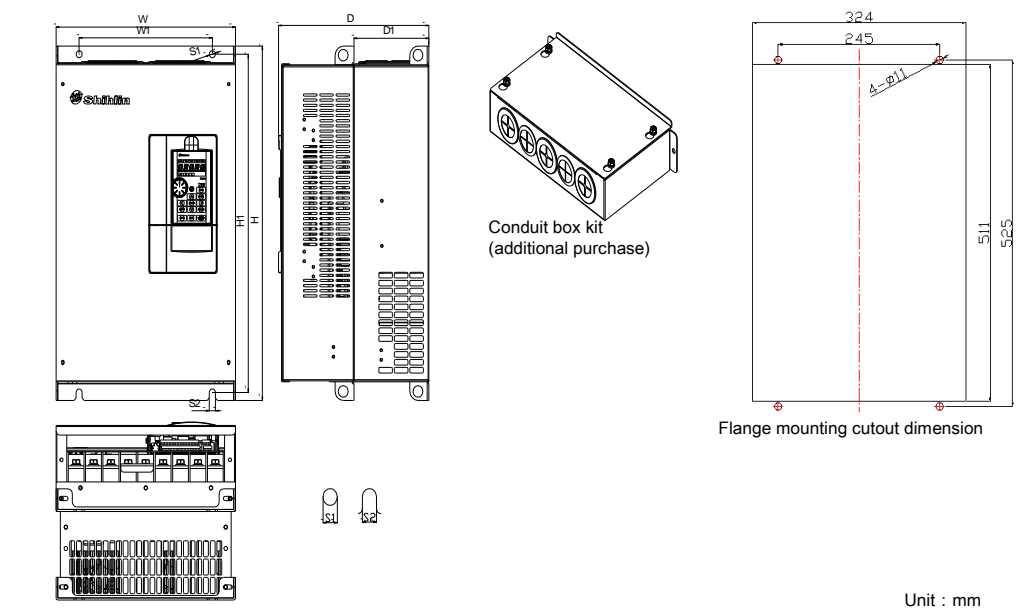

model	W	W1	H	H1	D	D1	S1	S2
SF3-043-55K/45KG	330.0	245.0	550.0	525.0	275.0	137.5	11.0	11.0
SF3-043-75K/55KG								
SF3-043-90K/75KG								

➤ Frame E

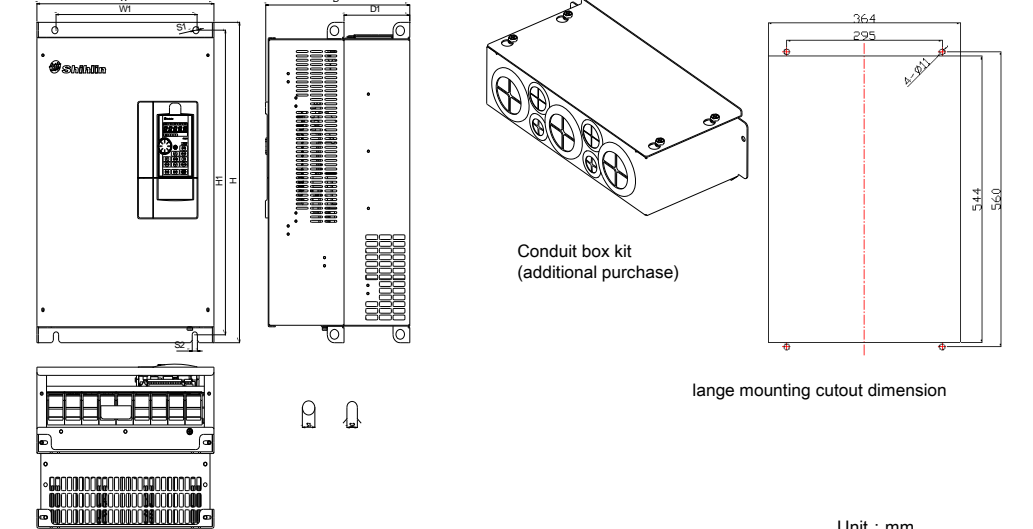

Model	W	W1	H	H1	D	D1	S1	S2
SF3-043-110K/90KG	370.0	295.0	589.0	560.0	300.0	137.5	11.0	11.0
SF3-043-132K/110KG								

➤ Frame F

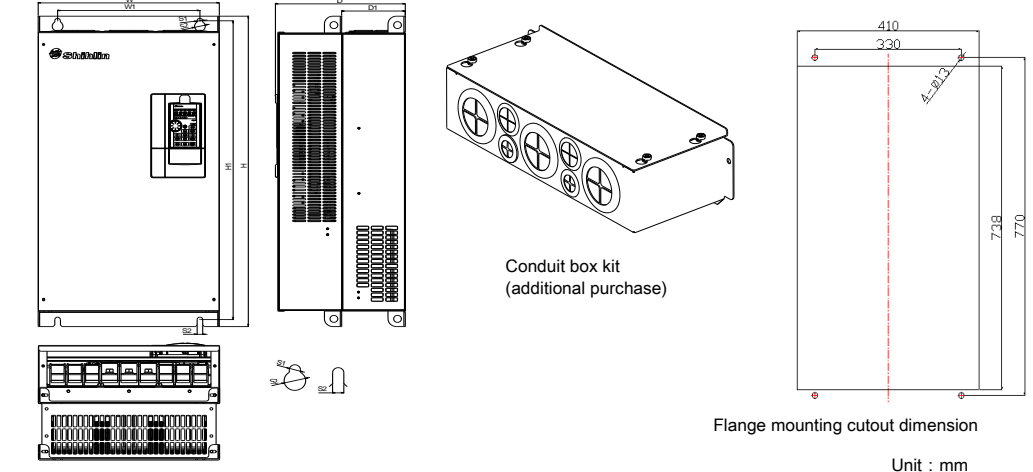

Model	W	W1	H	H1	D	D1	S1	S2	S3
SF3-043-160K/132KG	420.0	330.0	800.0	770.0	300.0	145.5	13.0	25.0	13.0
SF3-043-185K/180KG									

➤ Frame G

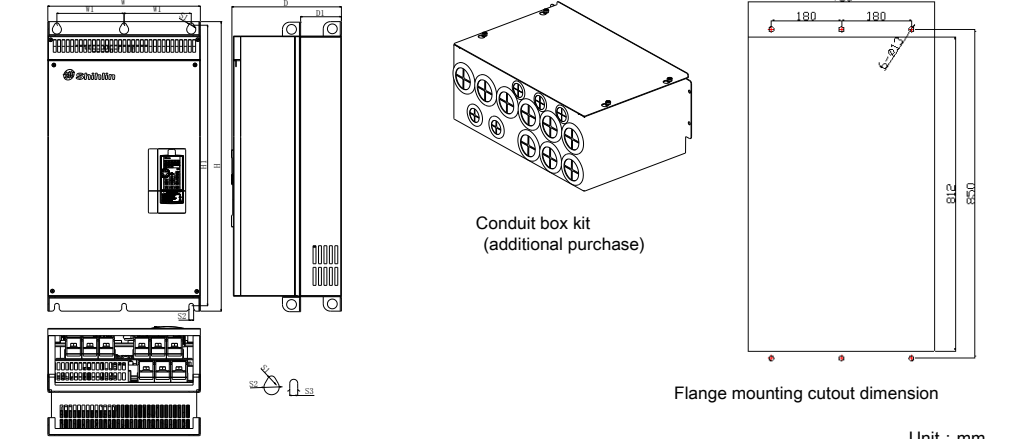

Model	W	W1	H	H1	D	D1	S1	S2	S3
SF3-043-220K/185KG	500.0	180.0	870.0	850.0	360.0	150.0	13.0	25.0	13.0
SF3-043-250K/220KG									
SF3-043-280K/250KG									

➤ Frame H

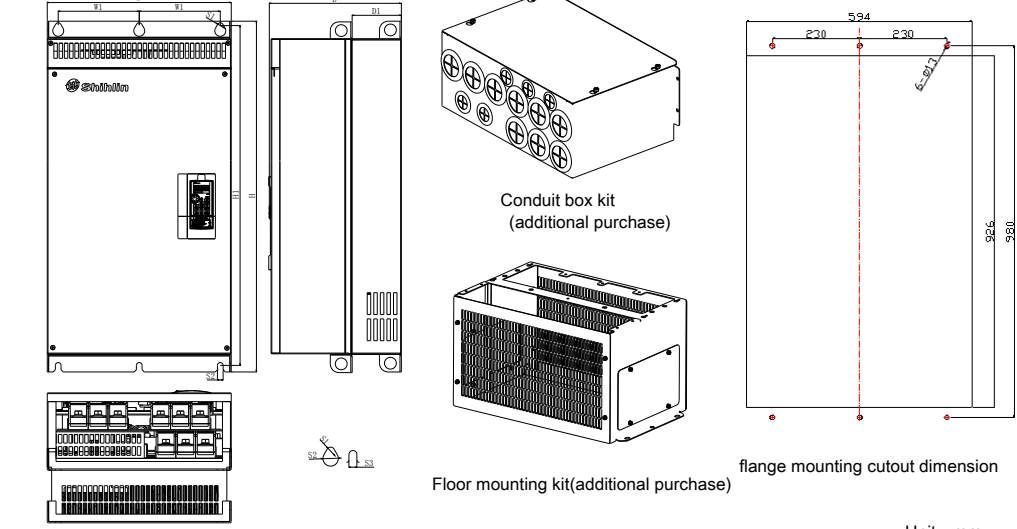

Model	W	W1	H	H1	D	D1	S1	S2	S3
SF3-043-315K/280KG	600.0	230.0	1000.0	980.0	400.0	181.5	13.0	25.0	13.0
SF3-043-355K/315KG									

8) Optional Equipment

Category	Name	Description	Order code	
Parameter unit	PU301	LED parameter unit	SNKPU301	
	PU301C	LCD parameter unit	SNKPU301C	
	Expansion card	PD302	Profibus-DP communication card	SNKPD302
		DN301	DeviceNet communication card	SNKDN301
		CP301	Canopen communication card	SNKCP301
		EP301	Ethernet communication card	SNKEP301
		EC301	EtherCAT communication card	SNKEC301
		EB362R	6 digital input, 2 relay output	SNKEB362R
	Other optional equipment	EB308R	8 relay output	SNKEB308R
		ACL****	AC reactor (External optional equipment for all models)	Refer Instruction Manual
DCL****		DC reactor (External optional equipment for all models)	Refer Instruction Manual	
FMK30*		Flange mounting kit (suitable for Frame A, B, C)	Refer Instruction Manual	
CTK301		Floor mounting kit (suitable for Frame H)	Refer Instruction Manual	
WBK30*		Conduit box kit (suitable for Frame D ~ H)	Refer Instruction Manual	
CBL1R5		The data transmission line (1.5 m)	SNKCBL1R5GTN2	
CBL03G		The data transmission line (3 m)	SNKCBL03GTN2	
CBL05G		The data transmission line (5 m)	SNKCBL05GTN2	
CBL10G		The data transmission line (10 m)	SNKCBL10GTN2	
SMK301	Snap mounting kit	SNKSMK301		
BKU-040	400V 45KW Brake Unit	SNKBKU04045K		
BKU-040	400V 160KW Brake Unit	SNKBKU040160K		

9) Others

➤ For convenient display, there is slight difference between the figures in this instruction and actual products, which will not affect the rights and interests of the customers.

➤ To improve our products, the parameters and contents may be modified, please contact the agent or refer to Shihlin websites (<http://automation.seec.com.tw/>) to download the latest version

